

# LEOPEST

LEO PNT ENGINEERING  
SUPPORT TOOLS

FINAL PRESENTATION



# Contents

- INTRODUCTION AND OBJECTIVES
- SYSTEM ARCHITECTURE AND USE CASES
- LEO CONSTELLATION DESIGN
- TEST CASES RESULTS OVERVIEW
- CONCLUSIONS
- NEXT STEPS

# INTRODUCTION AND OBJECTIVES

# Introduction and Objectives

The purpose of this project was to develop Engineering Tools to support the design, development, testing, maintenance and operations of LEO PNT Systems (LEOPEST).

The goal was to accelerate the design, development and planning of such systems focusing on early assessment of:

- Signal Generation, with a high degree of flexibility in terms of signal configurations;
- Signal Transmission and Recording, allowing the assessment of the impact of signal transmission and recording;
- Signal Processing, with the use of an experimental receiver access is granted to the tracking outputs being able to assess signal performance at correlation level;
- Performance Analysis, both at tracking level making use of the observables and tracking outputs (such as correlators value, discriminators outputs, among others) and at PVT.

# SYSTEM ARCHITECTURE AND USE CASES

# System Architecture and Uses Cases

## System Overview

Designed for **design**, **development**, and **planning** of LEO PNT systems.

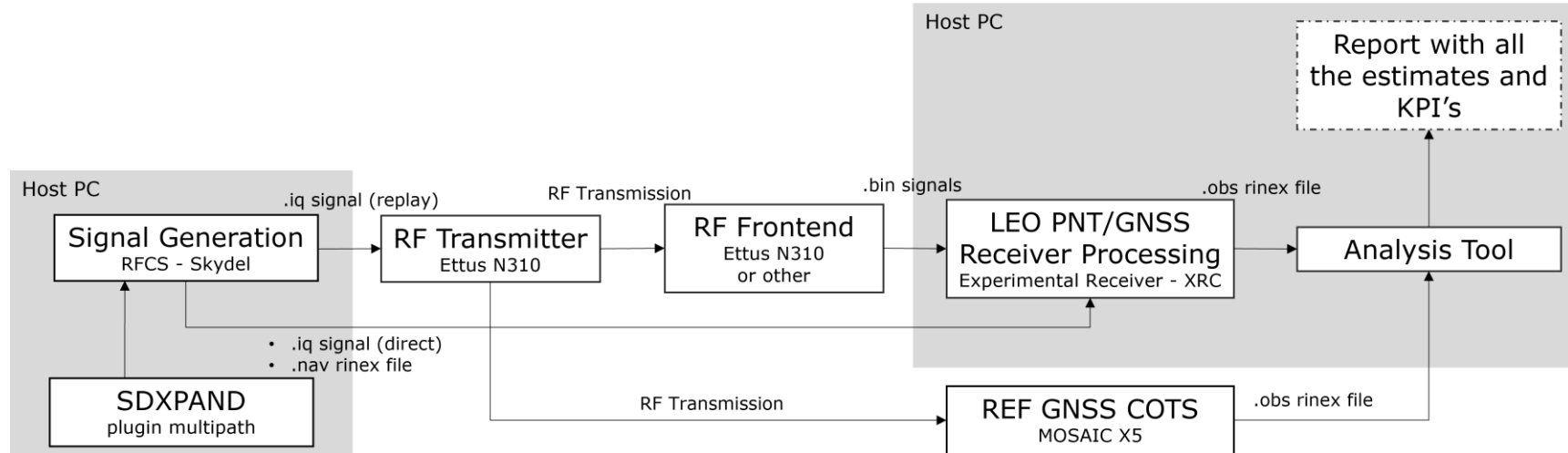

# System Architecture and Uses Cases

## Signal Generation

The used RFCS is based on **SKYDEL+SDXPAND**, allowing a high degree of freedom on signal configurability such as:

- Injection of multipath time series via SDXPAND.
- Simulation of receiver/transmission dynamics (including orbital dynamics).
- Configuration of signal modulation via m and n parameters of BOC(m,n) and BPSK(n).
- Signal power, bandwidth, central frequency, sampling frequency are configurable.
- High number of satellites in the same signal (up to 63).
- Code and data injection and modification is allowed.

# System Architecture and Uses Cases

## Signal Transmission/Recording

The transmission and recording of the signals from the RFCS was performed with two different Ettus USRP's:

- **Ettus USRP N310** (used for reception/recording and transmission) – High grade front end, allowing detailed signal analysis (due to the high sampling frequency and signal coherency).
- **Ettus USRP B205mini-i** (used for reception/recording only) – Mass market front end, representative of most used front ends.



# System Architecture and Uses Cases

## Signal Processing

The signal processing is performed with the GMV experimental receiver **XRC**.

Feature	Configurability
Tracking Signals	<ul style="list-style-type: none"><li>• GAL: E1, E5, E6</li><li>• GPS: L1C/A, L5Q</li><li>• LEO support per ICD</li></ul>
Acquisition	<ul style="list-style-type: none"><li>• Cold Start</li><li>• Warm Start</li><li>• Hot Start</li></ul>
Sampling Frequency	<ul style="list-style-type: none"><li>• [2, 102.3] MSps</li></ul>
Bit Depth	<ul style="list-style-type: none"><li>• [2, 4, 8, 12, 16] bits</li></ul>
Phase Tracking	<ul style="list-style-type: none"><li>• PLL</li><li>• FPLL</li><li>• FLL,</li></ul> <p>fully configurable in terms of order, bandwidth, coherent and non-coherent integration times</p>
Code Tracking	<ul style="list-style-type: none"><li>• Assisted/Stand Alone DLL</li><li>• EmL: [0.1, 1.5] chips</li></ul>
Processing Capabilities	<ul style="list-style-type: none"><li>• 90 channels (scalable via HW)</li></ul>

In parallel (when signals are supported) a reference receiver **MOSAIC X5** was used to have a performance benchmark.

# System Architecture and Uses Cases

## Performance Analysis

The analysis tool is in charge of generating the necessary KPI's and plots for performance assessment, both at processing level and at PVT:

Feature	Configurability
<b>Estimations</b>	<ul style="list-style-type: none"><li>• Code Delay</li><li>• Carrier Phase</li><li>• Doppler</li><li>• Carrier to Noise Ratio</li><li>• Pseudorange</li><li>• Computational time of Acquisition</li></ul>
<b>KPI's</b>	<ul style="list-style-type: none"><li>• Code (delay) and Carrier (phase and doppler) Accuracy via the 3rd order difference method</li><li>• Code (delay) and Carrier (phase and doppler) Jitter Percentile;</li><li>• Time to Acquire all Satellites</li><li>• Tracking Availability</li><li>• Service Availability</li></ul>

# System Architecture and Uses Cases

## Use Cases

The main aim is to simulate and evaluate LEO PNT system behavior across various configurations simulating different user scenarios. The following use cases were performed through the proposed system.

Use Case	Description
Double GNSS signal baseline	Reference case using GNSS only, no LEO satellites
Single Frequency LEO	Performance of single frequency standalone LEO system
Double Frequency LEO	Performance of double frequency standalone LEO system
Single Freq. LEO + Single Freq. GNSS	Combined single-frequency LEO + GNSS scenario
Double Freq. GNSS + Double Freq. LEO	High complexity with full system evaluation: Dual-frequency GNSS + dual-frequency LEO

Each use case can be further extended for different conditions (e.g. different dynamics, environment, full RF chain, mass market front end, among others), via the use of the different configurations present in the system chain of processing.

# LEO CONSTELLATION DESIGN

# LEO Constellation Design

## Overview

Two Constellations developed for Testing:

- **Custom** Starlink-Based Constellation
  - 21 satellites selected from real Starlink TLE data.
  - GPS satellites modified in Skydel to mimic LEO behavior.
  - Ensured continuous visibility over a 15-minute simulation.
  - Used in initial test cases (up to TC-004).
  
- **ESA**-Provided LEO Constellation
  - Two orbital possible configurations: 286 satellites at 750km altitude; 192 satellites at 1200km altitude.
  - Based on MATLAB structures from ESA.
  - Converted to TLE format via custom scripts.
  - Used in test cases TC-005 onwards.

# LEO Constellation Design

## ESA Constellation

A visibility analysis considering Madrid as a reference position was performed:

- **750km** constellation reached the Skydel's 63 satellite visibility limit faster (in ~47 minutes).
- Chosen for final test cases due to better performance at simulation scale.

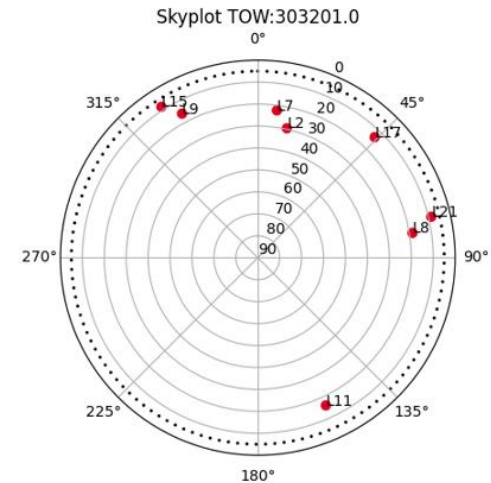
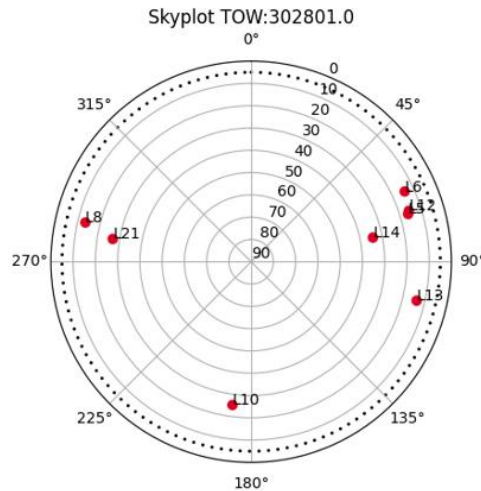
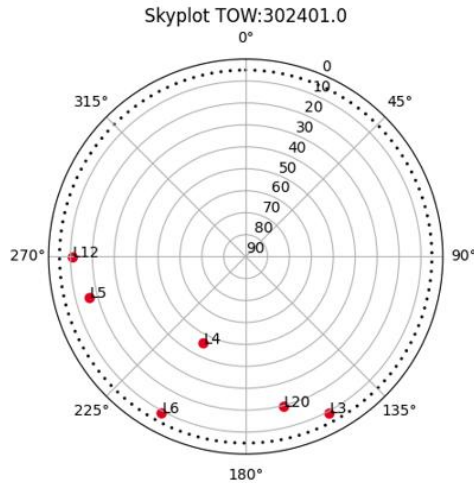

# TEST CASES

# Test Cases

## Overview

The tests were designed to incrementally introduce complexity—starting from baseline GNSS-only scenarios to multi-frequency, multipath-affected mixed GNSS+LEO configurations.

Test Case	Title	GNSS Signal Components	LEO Signal Components	Signal File Setup
TC-001	Double GNSS signal baseline	E1: CBOC(6,1,1/11) E5: AltBOC(15,10) GPS L1C/A: BPSK(1) GPS L5Q: BPSK(10)	N/A	RF recorded signal (Ettus N310)
TC-002	Single Frequency LEO in L Band	N/A	E5#1 Pilot: BPSK(10) E5#1 Data: BPSK(1)	IQ File direct (no RF)
TC-003	Single frequency GNSS + Single frequency LEO in L Band	E5: E5aQ (BPSK(10))	E5#1 Pilot: BPSK(10) E5#1 Data: BPSK(1)	RF recorded signal (Ettus B205mini-i)
TC-004	Single Frequency LEO in S Band	N/A	E5#1 Pilot: BPSK(10) E5#1 Data: BPSK(1)	IQ File direct (no RF)
TC-005	Single Frequency LEO in S Band with all signal components	N/A	S#1 Pilot: BPSK(5) S#1 Data: BPSK(1) FDMA S#1 Acquisition: BPSK(1/3) FDMA	IQ File direct (no RF)
TC-006	Dual Frequency LEO in S band and L Band	N/A	E5#1 Pilot: BPSK(10) E5#1 Data: BPSK(1) S#1 Pilot: BPSK(5) S#1 Data: BPSK(1) FDMA S#1 Acquisition: BPSK(1/3) FDMA	RF recorded signal (Ettus N310)
TC-007	Triple Frequency GNSS in L Band + LEO in S band and L Band	E1: CBOC(6,1,1/11) E5: AltBOC(15,10)	E5#1 Pilot: BPSK(10) E5#1 Data: BPSK(1) S#1 Pilot: BPSK(5) S#1 Data: BPSK(1) FDMA S#1 Acquisition: BPSK(1/3) FDMA	RF recorded signal (Ettus N310)

# Test Cases

## TC-001 – GNSS Baseline – Scenario Definition

- Reference Scenario for current GNSS capability benchmarking.
- Direct alignment assessment between N310 front-end + XRC receiver and COTS receiver.

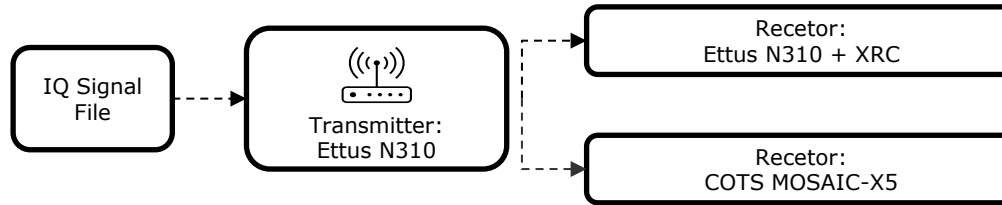

Parameter	Configuration
Modulations processed	<b>Galileo:</b> E1X, E5aQ <b>GPS:</b> L1C/A, L5Q
Signal source	RF transmitted and recorded (Ettus N310)
Sampling frequency / Bits	62.5 MSps / 8 Bits
User Environment/Dynamic	Urban Environment Pedestrian (with multipath)
Acquisition	Warm Start

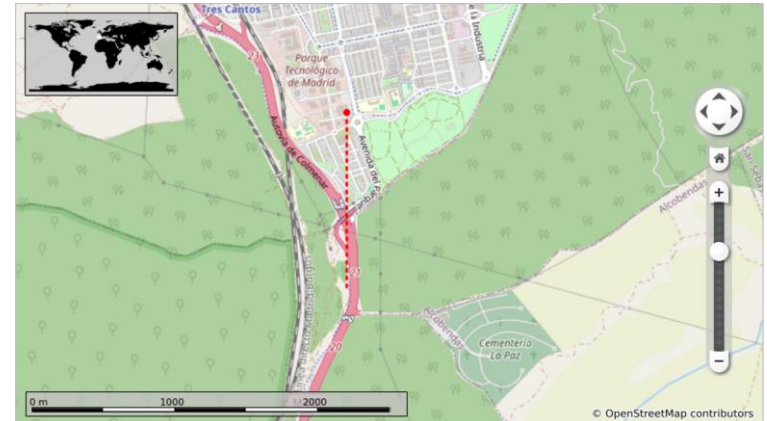

# Test Cases

## TC-001 – GNSS Baseline – IQ vs RF Coherency

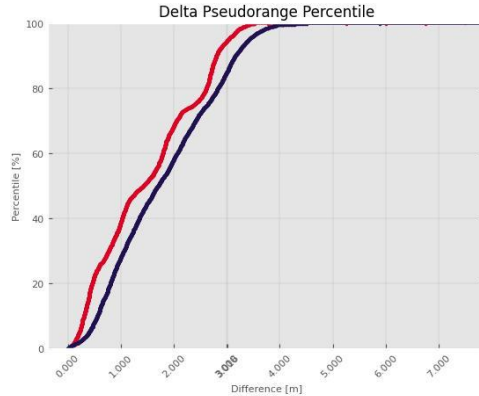

●	(Receiver: TC_001_IQ_MP, Receiver: TC_001_RF_MP_clockCorrected_PVTON): Galileo E1B + E1C Mean: 1.492, STD: 0.957, Percentile 95% :3.016
●	(Receiver: TC_001_IQ_MP, Receiver: TC_001_RF_MP_clockCorrected_PVTON): Galileo E5a-Q Mean: 1421.287, STD: 0.948, Percentile 95% :1422.822
●	(Receiver: TC_001_IQ_MP, Receiver: TC_001_RF_MP_clockCorrected_PVTON): GPS L1C/A Mean: 1.804, STD: 1.125, Percentile 95% :3.407
●	(Receiver: TC_001_IQ_MP, Receiver: TC_001_RF_MP_clockCorrected_PVTON): GPS L5-Q Mean: 1421.639, STD: 0.952, Percentile 95% :1423.167

- Bias and drift was found between the IQ and the recorded signal from the front end.
- With the integration of the PVT Engine in the tracking loops it was possible to compensate in the E1 band for the front end biases and drifts, allowing the validation of the coherency between the IQ and recorded file.

# Test Cases

## TC-001 – GNSS Baseline – IQ vs RF Coherency

### Pseudorange Difference between L1 C/A and L5Q

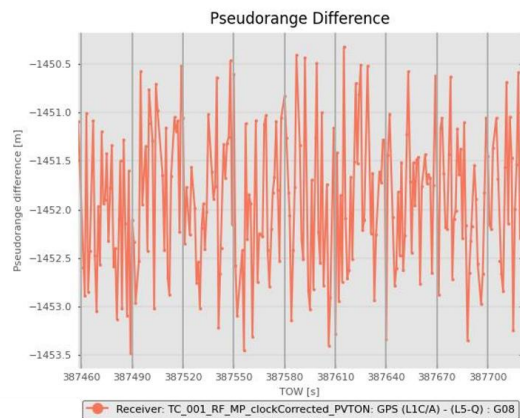

### Code Minus Carrier Estimation for E1X

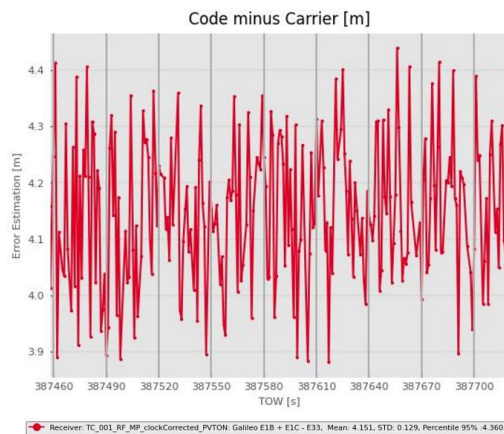

### PVT Results for IQ and RF Signals

PVT Metrics	TC_001_IQ	TC_001_RF
Minimum Error (m)	0.04	0.00
Maximum Error (m)	1.44	1.37
Error < 10m (%)	100.00	100.00
95-perc (m)	0.94	0.94
99.7-perc (m)	1.28	1.30
Mean Error (m)	0.48	0.49
STD (m)	0.25	0.25
RMSE (m)	0.54	0.55
Total Number of Points	801	801

- Consistency was also achieved in the RF signal, namely, between different bands (pseudorange difference of L1C/A with L5Q) and also in the same band (code minus carrier)
- With the integration of the PVT engine in the tracking loops it was possible to achieve coherency between the RF and IQ signals both at tracking and PVT Level.

# Test Cases

## TC-001 – GNSS Baseline – Tracking Outputs

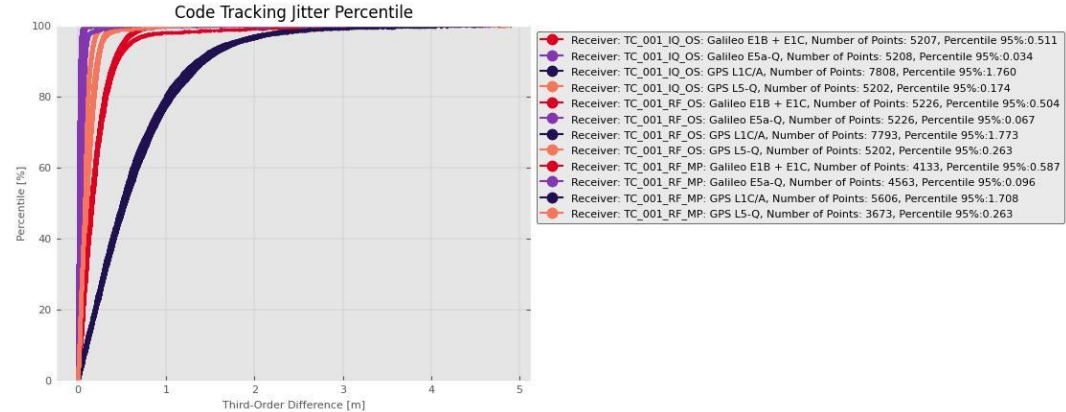
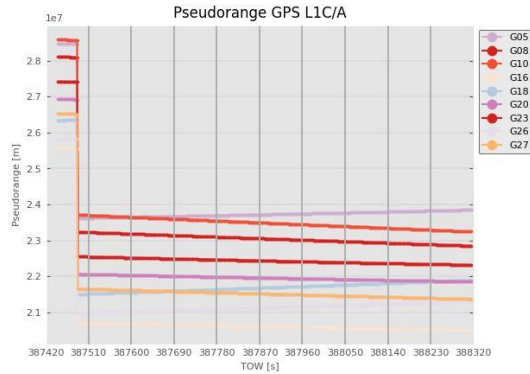

- Pseudorange correction with PVT clock bias and drift estimation.
- Code Tracking via 3rd order difference showed consistent results in terms of independent code jitter estimations and between modulations (E5aQ the more precise modulation and L1 C/A the less).
- Injection of multipath showed impact on jitter and CN0, demonstrated the system's ability to assess environmental signal distortions.

# Test Cases

## TC-001 – GNSS Baseline – Tracking Outputs

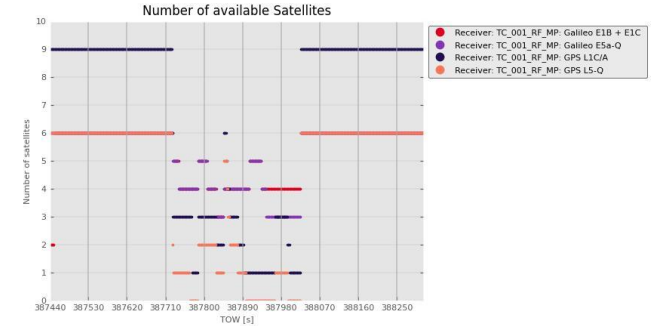
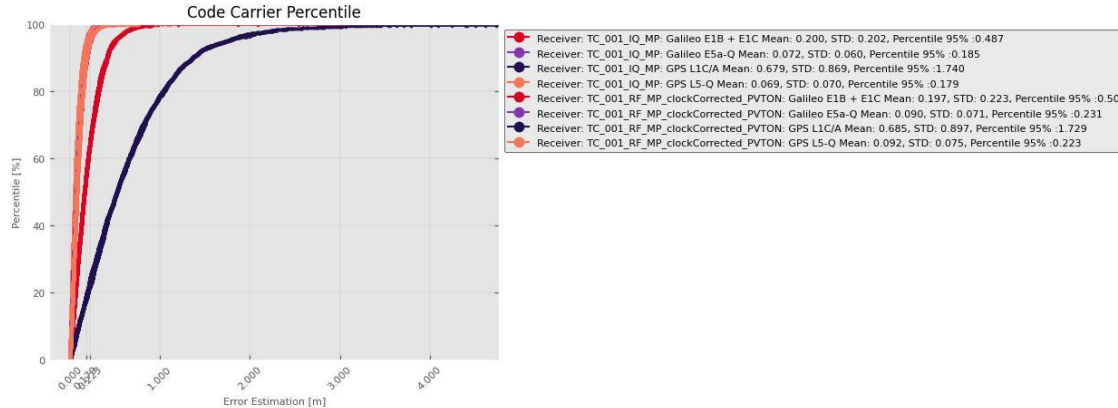

- Code Carrier metric in line with the code jitter, proving consistency between carrier and code estimates.
- Injection of multipath is also felt with the reduction of the visible satellites during the multipath section.

# Test Cases

## TC-002 – Single Frequency LEO in L Band – Scenario Definition and Results

Parameter	Configuration
Modulations processed	LEO: E5#1 Pilot (BPSK(10)) + E5#1 Data (BPSK(1))
Signal source	Direct IQ
Sampling frequency / Bits	50 MSps / 16 Bits
User Environment/Dynamics	Open Sky Pedestrian
Multipath	N/A
Acquisition	Warm Start

### High-Dynamics Handling:

- Correctly tracked Doppler shifts up to  $\pm 30$  kHz
- Loop filters maintained carrier lock through rapid variation

### Sky Coverage Confirmation:

- $\geq 4$  satellites visible at all times
- Confirms functional LEO constellation setup

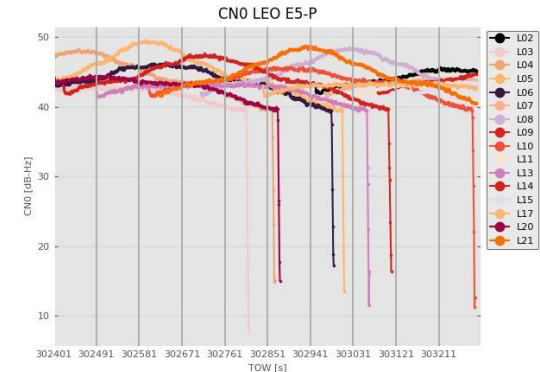
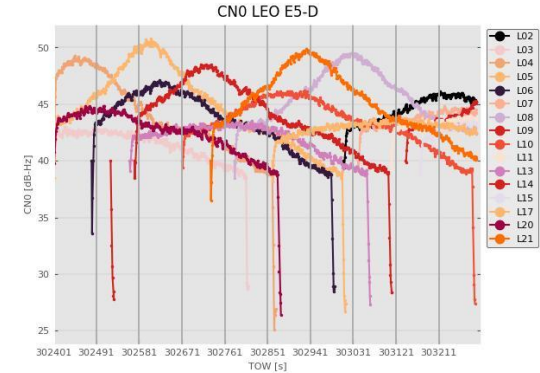

# Test Cases

## TC-002 – Single Frequency LEO in L Band – Tracking Outputs

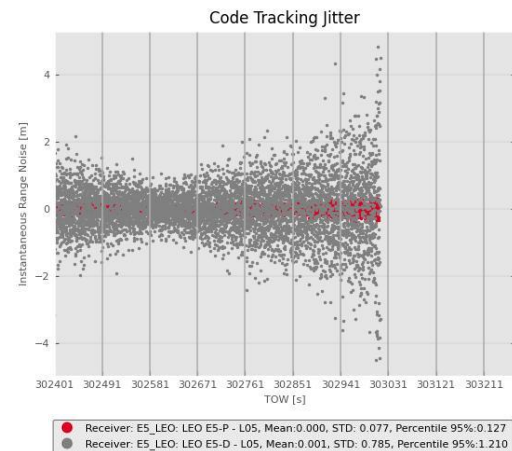
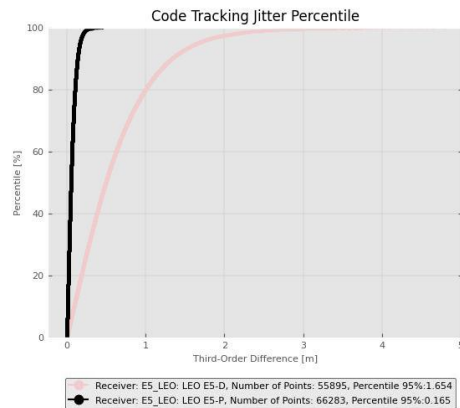
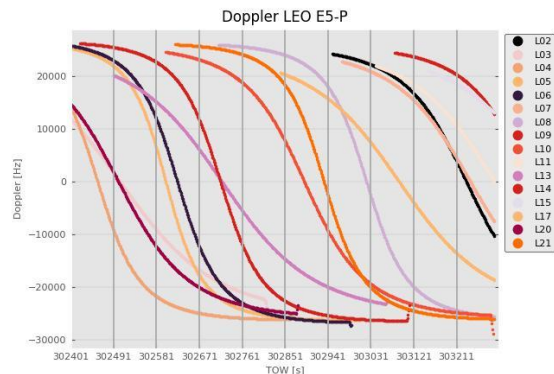

### Code Tracking Performance:

- BPSK(10) (pilot): Low jitter ( $\sim 0.2$  m)
- BPSK(1) (data): Higher jitter ( $\sim 1.7$  m), as expected

### Computational performance:

- Time ratio:  $\sim 5.7\times$  real-time
- Average active channels: 17

With LEO constellation, processing remained efficient, with moderate computational load and stable tracking.

# Test Cases

## TC-003 – Single Frequency GNSS + Single Frequency LEO in L Band

Parameter	Configuration
Modulations processed	LEO: E5#1 Pilot (BPSK(10)) + E5#1 Data (BPSK(1)) GNSS: Galileo E5aQ (BPSK(10))
Signal source	IQ → RF replayed (Ettus N310) → RF recorded (Ettus B205mini-i)
Sampling frequency / Bits	50 MSps / 8 Bits
User Environment/Dynamics	Open Sky Vehicular
Multipath	N/A
Acquisition	Warm Start

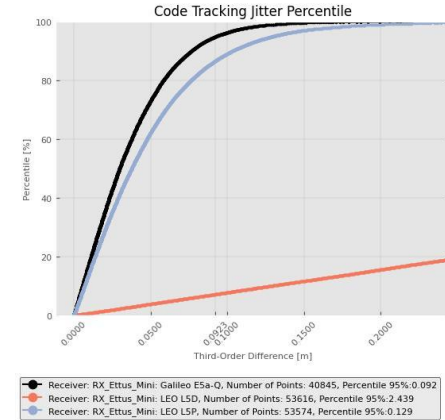

### Signal Coexistence:

- Successfully processed E5aQ (GNSS) and E5#1 (LEO) in same band, with no intermodulation or mutual degradation in observables.

### Performance Validation Under Vehicular Dynamics:

- Introduced motion: ~50 km/h
- Code jitter within expected bounds
- LEO signals required tighter tracking loops (3rd-order PLL) due to fast dynamics

# Test Cases

## TC-004 – Single Frequency LEO in S Band

Parameter	Configuration
Modulations processed	LEO: E5#1 Pilot (BPSK(10)) + E5#1 Data (BPSK(1))
Signal source	Direct IQ
Sampling frequency / Bits	50 MSps / 16 Bits
User Environment/Dynamics	Open Sky Static
Multipath	N/A
Acquisition	Cold Start

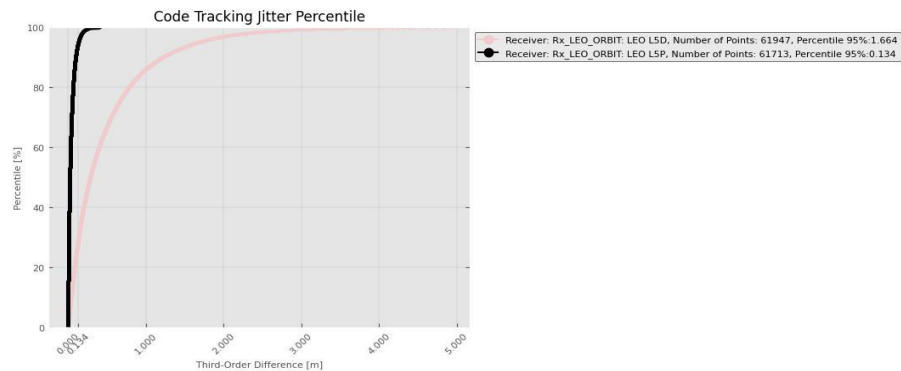

### Increased Doppler Range:

- Higher frequency translated into higher Doppler shifts (up to  $\pm 60$  kHz Doppler)
- Required wide acquisition search during cold acquisition (90000Hz range with 25Hz steps)

### Cold Start Evaluation:

- Successful acquisition without aided navigation data
- Resulted in increased computational time and longer acquisition duration

### Computational performance:

- Time ratio:  $19.4 \times$  real-time
- Average active channels: 16

Cold start and large Doppler step search significantly increased computational demands

# Test Cases

## TC-005 – Single Frequency LEO in S Band All Signal Components

Parameter	Configuration
Modulations processed	LEO: S#1 Pilot (BPSK(5)), S#1 Data (BPSK(1), FDMA), S#1 Acquisition (BPSK(1/3), FDMA)
Signal source	Direct IQ
Sampling frequency / Bits	12.5 MSps / 16 Bits
User Environment/Dynamics	Open Sky Pedestrian
Multipath	N/A
Acquisition	Warm Start

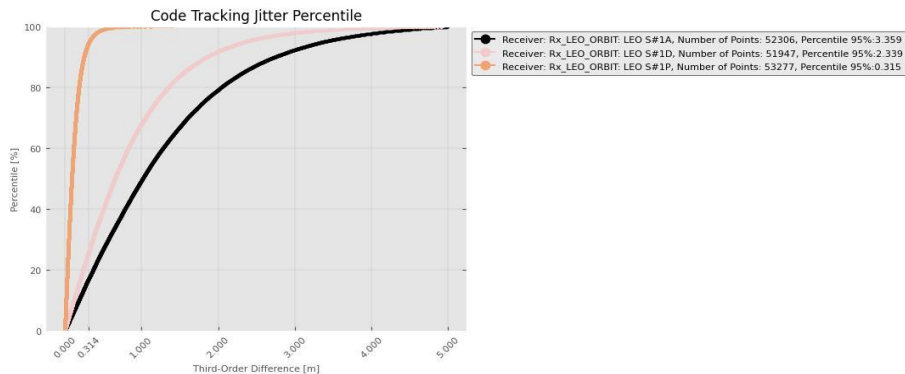

### FDMA Signal Processing Validated:

- S#1\_Data: 95th percentile jitter  $\sim 1$  m lower than S#1\_Acq (narrower ACF)
- S#1\_Acq: Higher jitter due to wider ACF
- S#1\_Pilot: Best performance  $\rightarrow 0.315$  m jitter

### Constellation Scalability

- Scenario validated the use of a 31-satellite constellation tailored for FDMA compatibility with Skydel's signal limit

### Computational performance

- Time ratio:  $4.87 \times$  real-time
- Average active channels: 21

Warm start enabled moderate acquisition times (16 s), confirming the scalability of the receiver to multi-component signals.

# Test Cases

## TC-006 – Dual Frequency LEO in S and L Bands

Parameter	Configuration
Modulations processed	LEO L-band: E5#1 Pilot (BPSK(10)), E5#1 Data (BPSK(1)) LEO S-band: S#1 Pilot (BPSK(5)), S#1 Data (BPSK(1), FDMA), S#1 Acquisition (BPSK(1/3), FDMA)
Signal source	IQ generated → RF replayed → RF recorded (Ettus N310)
Sampling frequency / Bits	25 MSps (L band), 12.5 MSps (S band) / 16 Bits
User Environment/Dynamics	Open Sky Static
Multipath	N/A
Acquisition	Warm Start

### Increased System Load:

- Higher tracking and acquisition loads (29 channels, 150 acquisitions).
- Receiver maintained stable 7.5× real-time processing capability

### Tracking Coherency Across Bands:

- CNO and jitter followed consistent patterns across bands
- Pilot signals always outperformed data and acquisition components in tracking stability due to its narrowest ACF

### Computational performance:

- Time ratio: 7.5 × real-time
- Average active channels: 29

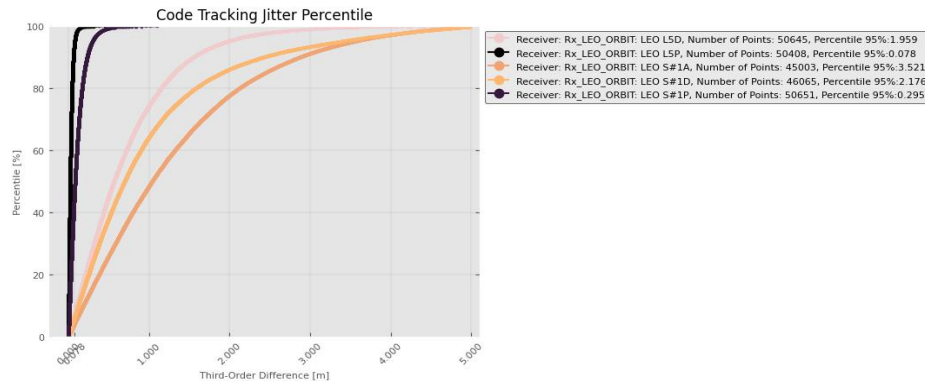

# Test Cases

## TC-007 – Triple Frequency GNSS in L Band + LEO in S and L Band – Overview

Parameter	Configuration
Modulations processed	Galileo: E1X (E1B + E1C, CBOC), E5aQ (AltBOC) LEO L-band: E5#1 Pilot (BPSK(10)), E5#1 Data (BPSK(1)) LEO S-band: S#1 Pilot (BPSK(5)), S#1 Data (BPSK(1), FDMA), S#1 Acquisition (BPSK(1/3), FDMA)
Signal source	Direct IQ
Sampling frequency / Bits	25 Msps (E5), 12.5 Msps (other signals) / 16 Bits
User Environment/Dynamics	Urban Environment Static
Multipath	Yes
Acquisition	Warm Start

### Coexistence of Modulation Types:

- 7 simultaneous modulation types tested (FDMA + non-FDMA)
- Confirmed full support by XRC receiver

### Multipath

- Injected into GNSS E1X, E5aQ, and LEO S#1\_Pilot (non FDMA components), created observable disruptions in all estimates
- Receiver showed good recovery behavior with reacquisition cycles executed within a few seconds

### Code Jitter

- Increased significantly (e.g., E5aQ from 0.02 m to 0.54 m)
- Performance still within thresholds that allow usable navigation solutions

### Computational performance:

- Time ratio: - L1 + L5 bands: 4× real-time; S band: 6× real-time
- Average active channels: 15 L band + 20 S band

# Test Cases

## TC-007 - Triple Frequency GNSS in L Band + LEO in S and L Band - Results

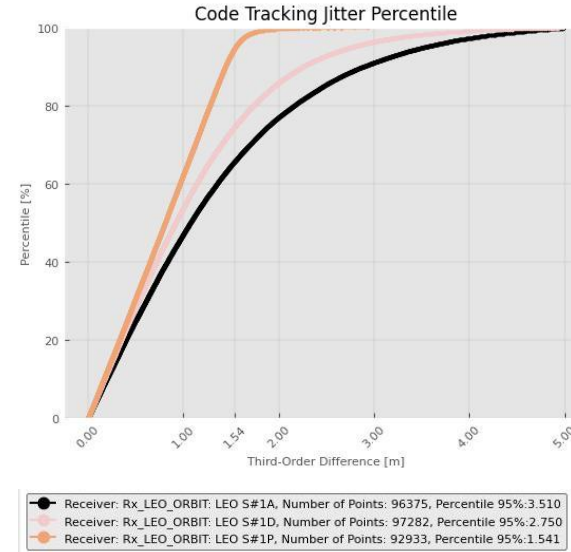
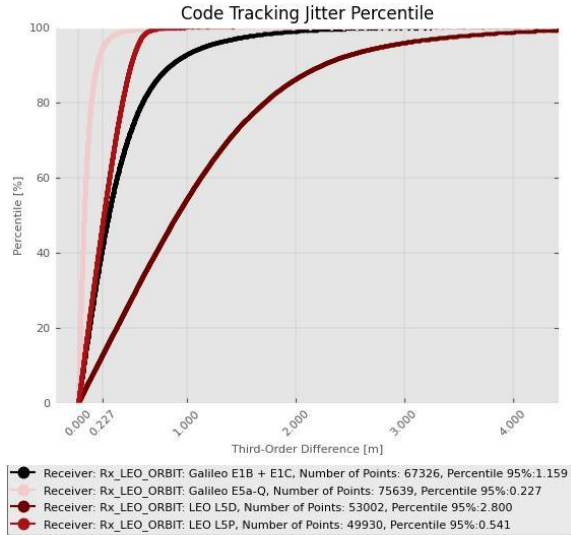

- Modulation accuracy is according to expectations, and previous test cases.

# CONCLUSIONS

# Conclusions

## Signal Generation

- GNSS+LEO signals across E1, E5, and S bands were successfully generated and processed, with configurable constellations (GPS-based and ESA-developed LEO constellations), modulation types (including with FDMA), and high dynamic environments.

## Validation

- IQ vs. RF tests revealed biases, corrected with the integration of the PVT engine in the tracking receiver. Tracking observables (CNO, code/carrier jitter) remained consistent across different test cases with different conditions and configurations.

## Receiver Performance

- XRC maintained accurate tracking in high-dynamic and multipath scenarios, with the overall performance matching expectations across modulation types and different dynamics of both the transmitter and the receiver.

# Conclusions

## Multipath & Visibility

- Effective handling of multipath and visibility conditions, with a valid injection of multipath time series across different sets of modulations.

## Computation

- Processing scaled predictably with scenario complexity (acquisition configuration and number of channels); even the most demanding test case (TC-007, triple frequency, 7 different modulations) confirmed offline feasibility ( $\sim 5-6\times$  real-time).
- Initial real-time replay issues (even single channel) were solved by implementing a high-speed buffer on the ETTUS device, allowing uninterrupted data flow via 10Gbps link.

## Receiver Benchmarking

- GMV receiver matched COTS performance in baseline tests, validating its performance and readiness for accurate assessment and testing. Analysis tool delivered full KPI coverage across all test cases allowing validation and verification of the different details present in the processing chain.

# NEXT STEPS

# Next Steps

## Recommendations and Way Forward

### Signal Generation

- Generation of full ICD signals in different central frequencies (C band, among others) with different signal specifications should be considered.
- Native multipath timeseries should be present in the signal generation options.

### Radios

- Integrated tracking loops with PVT Engine is advised for RF chain if phase coherency is necessary across the different bands and modulations recommended.
- Investigation on simultaneous transmission and recording on the same host PC should be considered. When tried in TC-006 it led to underflows and sample loss, mitigated by sequential playback and offline processing.

### Processing (XRC)

- Split heavy processing loads across multiple runs (or divide the processing of the signal by file, and also by selecting a specific number of satellites or modulations) when RAM/GPU limits are reached.
- Integration of full LEO ICD Signals.
- Feature of tracking BPSK(n), BOC(n,m) signals by m and n configuration

# Thank you

LEOPEST Team